



光电耦合器

OPTOCOUPLER

产品规格书
Product Data Sheet

Si-6N137

高速光耦系列

Si-6N137 High-speed Series

Si DCC
Release

贵州硅耐光电有限公司

GuiZhou Silicon Nice Optoelectronic Co., Ltd.

描述 Description

Si-6N137 高速光耦系列有一个发光二极管，通过红外光与高速收光 IC 耦合并封装在 DIP-8/SMD-8 封装中。输出端收光 IC 采用带有肖特基箝位的集电极开路结构，这种设计提供了出色的交流和直流电路隔离能力，同时实现了 TTL 兼容性。

The Si-6N137 high-speed optocoupler series has a infrared emitting diode, which is optically coupled to an integrated high-speed photo detector, and is incorporated in a DIP-8/SMD-8 package. The output of the detector IC is an open collector schottky clamped transistor. This design provides excellent AC and DC circuit isolation while achieving TTL compatibility.

典型应用 Typical Applications

- 高速逻辑系统隔离
Isolation of high speed logic systems
- 电机驱动中的功率晶体管隔离
Power transistor isolation in motor drives
- 用于 A/D、D/A 转换时的数字隔离
Digital isolation for A/D, D/A conversion
- 用于微处理器系统、计算机及其外围设备之间的接口
Microprocessor system interfaces, computer-peripheral interfaces

特性 Features

- 高速率：10MBd
High speed: 10 MBd
- 兼容 LVTTTL/LVCMOS 电平
LVTTTL/LVCMOS Compatible

真值表 Truth Table		
发光二极管 LED	使能端 Enable	输出 Output
ON	H or NC	L
OFF	H or NC	H
ON	L	H
OFF	L	H

封装与功能图 Package and Functional Diagram

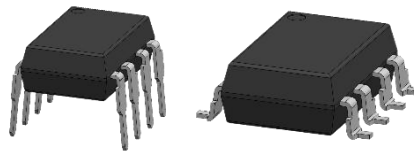
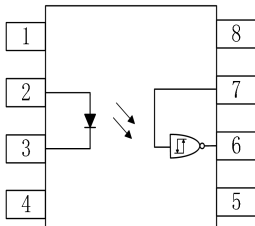
封装 Package	内部连接图 Internal Connection Diagram	引脚分配 Pin Assignment
 DIP8 SMD8		1: NC 5:Gnd 2: Anode 6:V _O 3: Cathode 7:V _E 4: NC 8:V _{CC}



安规与绝缘参数 Safety and Insulation Ratings

参数 Parameter		符号 Symbol	数值 Value	单位 Unit
最大额定隔离电压 Maximum Rated Withstanding Isolation Voltage	According to UL1577, t = 1 min	V _{ISO}	5000	V _{RMS}
最大瞬态隔离电压 Maximum Transient Isolation Voltage	According to DIN EN 60747-5-5	V _{IOTM}	7000	V _{peak}
最大峰值重复隔离电压 Maximum Repetitive Peak Isolation Voltage	According to DIN EN 60747-5-5	V _{IORM}	1500	V _{peak}
爬电距离 Creepage Distance	/	L	>7.6	mm

极限参数 Absolute Maximum Ratings (T_{amb}=25°C)

参数 Parameter		符号 Symbol	极限值 Rating	单位 Unit
输入端 Input	正向电流 Forward Current	I _F	50	mA
	反向电压 Reverse Voltage	V _R	6	V
	输入功耗 Input Power Dissipation	P _{IN}	100	mW
输出端 Output	电源电压 Supply Voltage	V _{CC}	7	V
	集电极输出电压 Output Collector Voltage	V _O	7	V
	集电极输出电流 Output Collector Current	I _O	50	mA
	集电极输出功耗 Output Collector Power Dissipation	P _O	85	mW
总功耗 Total Power Dissipation		P _{tot}	100	mW
工作温度 Operating Temperature		T _{amb}	-40~85	°C
存储温度 Storage Temperature		T _{stg}	-55~125	°C
焊接温度 Soldering Temperature		T _{slid}	260	°C

推荐的工作条件 Recommended Operating Conditions

参数 Parameter	符号 Symbol	最小值 Min.	最大值 Max.	单位 Unit
电源电压 Power Supply Voltage	V _{CC}	4.5	5.5	V
低电平输入电流 Low Level Input Current	I _{FL}	0	250	uA
高电平输入电流 High Level Input Current	I _{FH}	5	15	mA
输出上拉电阻 Output Pull-up Resistor	R _L	330	4k	Ω
使能端低电平电压 Low Level Enable Voltage	V _{EL}	0	0.8	V
使能端高电平电压 High Level Enable Voltage	V _{EH}	2	V _{CC}	V
扇出系数(每通道负载电阻 1kΩ)Fan out(at R _L =1kΩ per channel)	N	-	8	TTL Loads
工作温度 Operating Temperature	T _A	-40	+85	°C



产品特性参数 Electro-optical Characteristics ($T_{amb}=25^{\circ}C$)

参数 Parameter		测试条件 Test Conditions	符号 Symbol	最小值 Min.	典型值 Typ.	最大值 Max.	单位 Units
输入端 Input	正向电压 Forward Voltage	$I_F=10mA$	V_F	-	1.37	1.8	V
	反向电压 Reverse Voltage	$I_R=10\mu A$	B_{VR}	5	-	-	V
	输入电容 Input Capacitance	$V_F=0V, f=1MHz$	C_{IN}	-	60	-	pF
	正向电压温度系数 Temperature Coefficient of Forward Voltage	$I_F=10mA$	$\Delta V_F/\Delta T_A$	-	-1.4	-	mV/ $^{\circ}C$
输出端 Output	高电平电源电流 High Level Supply Current	$I_F=0mA$ $V_{CC}=5.5V$ $V_E=0.5V$	I_{CCH}	-	6.5	10	mA
	低电平电源电流 Low Level Supply Current	$I_F=10mA$ $V_{CC}=5.5V$	I_{CCL}	-	8.5	13	mA
传输特性 Transfer Characteristics	输入阈值电流 Input Threshold Current	$V_{CC}=5.5V$ $V_O=0.6V$ $I_O=13mA$ $V_E=2.0V$	I_{FT}	-	2.6	5	mA
	低电平使能电流 Low Level Enable Current	$V_{CC}=5.5V$ $V_E=0.5V$	I_{EL}	-	-0.8	-1.6	mA
	高电平使能电流 High Level Enable Current	$V_{CC}=5.5V$ $V_E=2.0V$	I_{EH}	-	-0.6	-1.6	mA
	高电平使能电压 High Level Enable Voltage	$I_F=10mA$ $V_{CC}=5.5V$	V_{EH}	2.0	-	-	V
	低电平使能电压 Low Level Enable Voltage	$I_F=10mA$ $V_{CC}=5.5V$	V_{EL}	-	-	0.8	V
	高电平输出电流 High Level Output Current	$I_F=250\mu A$ $V_{CC}=V_O=5.5V$ $V_E=2.0V$	I_{OH}	-	-	100	μA
	低电平输出电压 Low Level Output Voltage	$I_F=5mA$ $V_{CC}=5.5V$ $I_{OL(sinking)}=13mA$ $V_E=2.0V$	V_{OL}	-	0.32	0.6	V
隔离特性 Isolation Characteristics	输入-输出绝缘漏电流 Input-Output Insulation Leakage Current	45% RH, $t = 5 s, V_{I-O}$ $V_{I-O} = 3 kV dc,$ $T_A = 25^{\circ}C$	I_{I-O}	-	-	1	μA
	输入-输出隔离电阻 Input-Output Resistance	$V_{I-O}=500V,$ 40~60%R.H.	R_{I-O}	-	10^{14}	-	Ω
	输入-输出隔离电容 Input-Output Capacitance	$f=1MHz, T_A=25^{\circ}C$	C_{I-O}	-	1.0	-	pF

开关特性参数 Switching Characteristics ($T_{amb}=25^{\circ}C$)

参数 Parameter	测试条件 Test Conditions	符号 Symbol	最小值 Min.	典型值 Typ.	最大值 Max.	单位 Units
输出高电平传输延时 Propagation Delay Time to Output High Level	$I_F=7.5mA$ $V_{CC}=5.0V$ $R_L = 350\Omega$ $C_L = 15pF$ $T_A=25^{\circ}C$	t_{PLH}	-	45	75	ns
输出低电平传输延时 Propagation Delay Time to Output Low Level		t_{PHL}	-	40	75	ns
脉宽失真 Pulse Width Distortion		$ t_{PLH} - t_{PHL} $	-	5	35	ns
输出上升时间 Output Rise Time		t_r	-	30	-	ns
输出下降时间 Output Fall Time		t_f	-	8.5	-	ns
输出高电平共模抑制因子 Common Mode Transient Immunity at High Output Level	$I_F=0mA$ $V_{CC}=5.0V$ $R_L = 350\Omega$ $V_O=2.0V$ $ V_{CM} =1kV$ $T_A=25^{\circ}C$	$ CM_H $	5	-	-	kV/us
输出低电平共模抑制因子 Common Mode Transient Immunity at Low Output Level	$I_F=7.5mA$ $V_{CC}=5.0V$ $R_L = 350\Omega$ $V_O=0.8V$ $ V_{CM} =1kV T_A=25^{\circ}C$	$ CM_L $	5	-	-	kV/us
输出高电平使能传输延时 Enable Propagation Delay Time to Output Low Level	$I_F=7.5mA$ $V_{CC}=5.0V$ $V_{EH}=3.3V$ $R_L = 350\Omega$ $C_L = 15pF$ $T_A=25^{\circ}C$	t_{EHL}	-	15	-	ns
输出低电平使能传输延时 Enable Propagation Delay Time to Output High Level	$I_F=7.5mA$ $V_{CC}=5.0V$ $V_{EH}=3.3V$ $R_L = 350\Omega$ $C_L = 15pF$ $T_A=25^{\circ}C$	t_{ELH}	-	20	-	ns

典型特性曲线 Typical Characteristics Curves

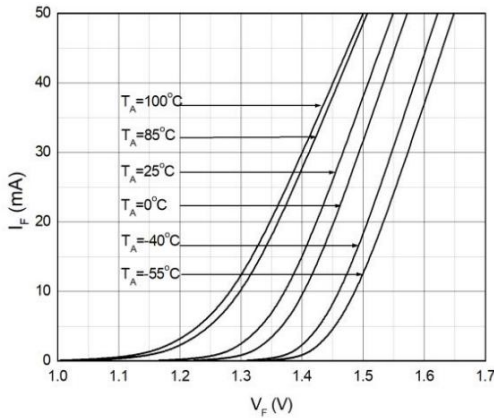

图例 1-正向电流与正向电压曲线图

Fig. 1 - Forward Current vs. Forward Voltage

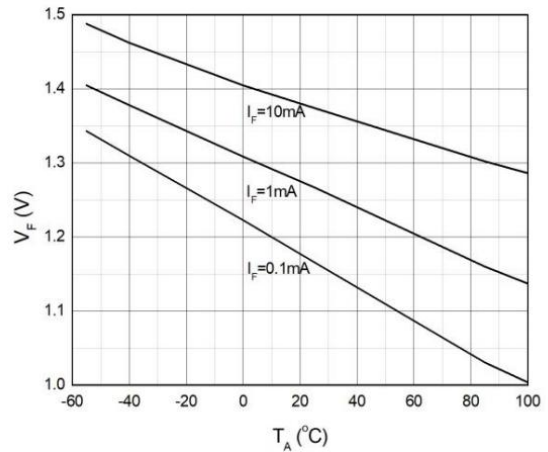

图例 2-正向电压与环境温度曲线图

Fig. 2 - Forward Voltage vs. Ambient Temperature

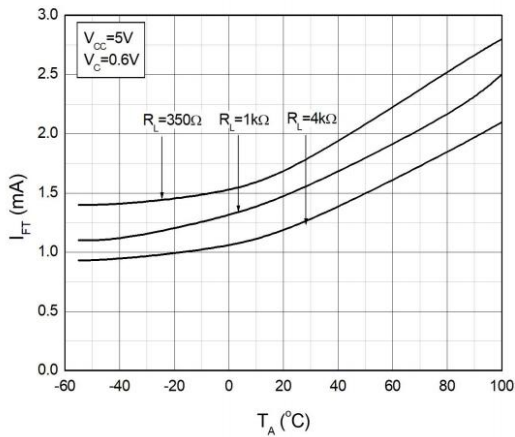

图例 3-输入阈值电流与环境温度曲线图

Fig. 3 - Input Threshold Current vs. Ambient Temperature

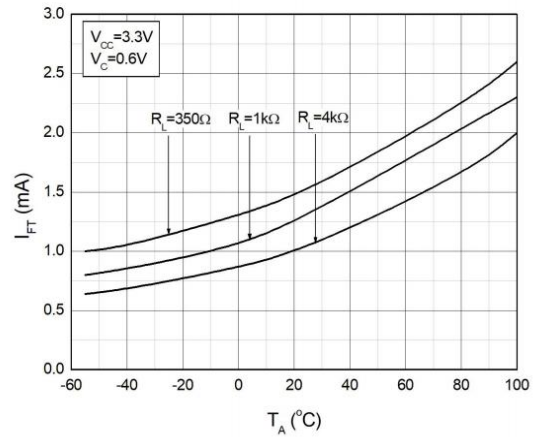

图例 4-输入阈值电流与环境温度曲线图

Fig. 4 Input Threshold Current vs. Ambient Temperature

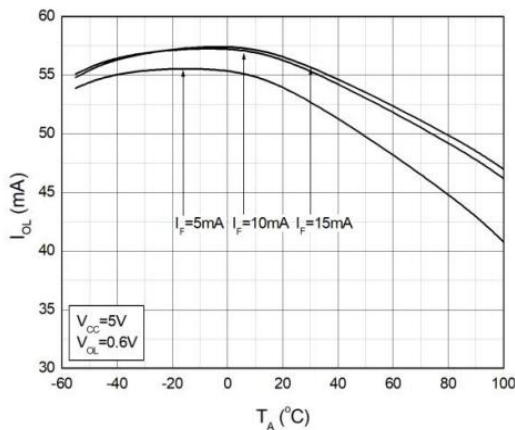

图例 5-低电平输出电流与环境温度曲线图

Fig.5-Low Level Output Current vs. Ambient Temperature

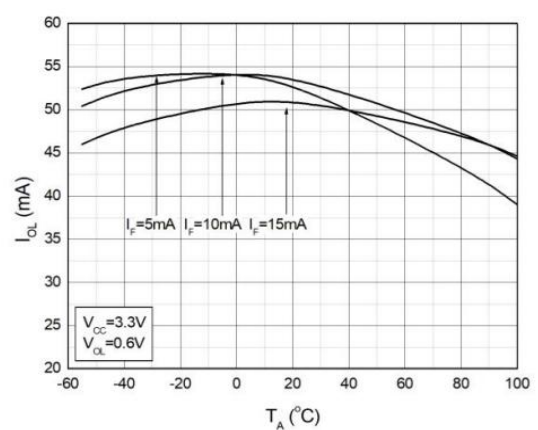

图例 6-低电平输出电流与环境温度曲线图

Fig.6-Low Level Output Current vs. Ambient Temperature

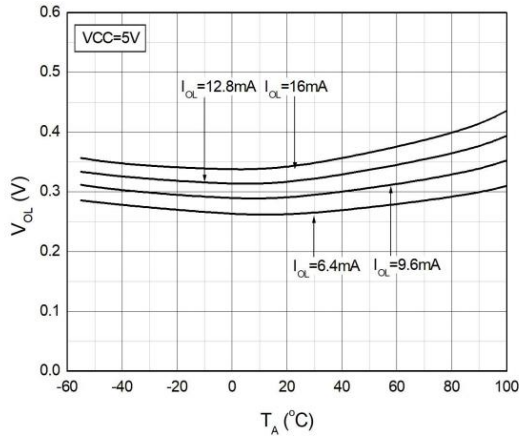

图例 7-低电平输出电压与环境温度曲线图

Fig. 7- Low Level Output Voltage vs. Ambient Temperature

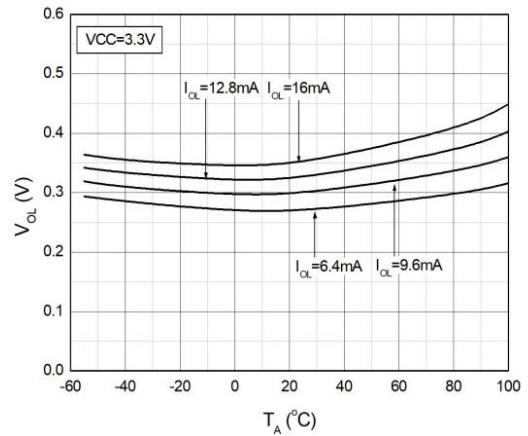

图例 8-低电平输出电压与环境温度曲线图

Fig. 8- Low Level Output Voltage vs. Ambient Temperature

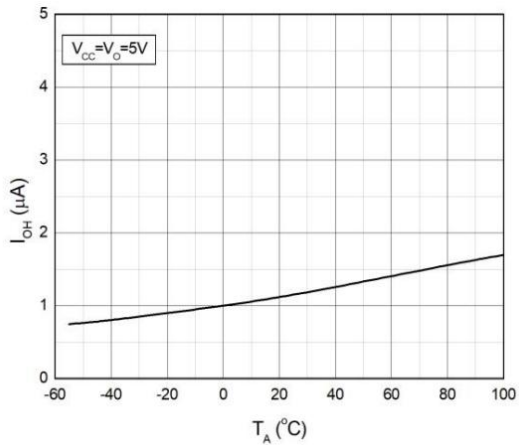

图例 9-高电平输出电流与环境温度曲线图

Fig. 9- High Level Output Current vs. Ambient Temperature

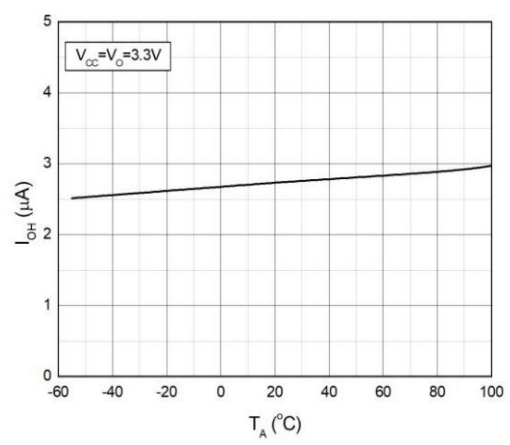

图例 10-高电平输出电流与环境温度曲线图

Fig. 10- High Level Output Current vs. Ambient Temperature

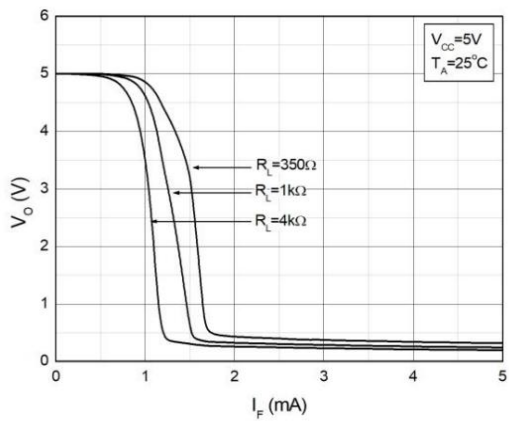

图例 11-输出电压与正向电流曲线图

Fig11-Output Voltage vs. Forward Current

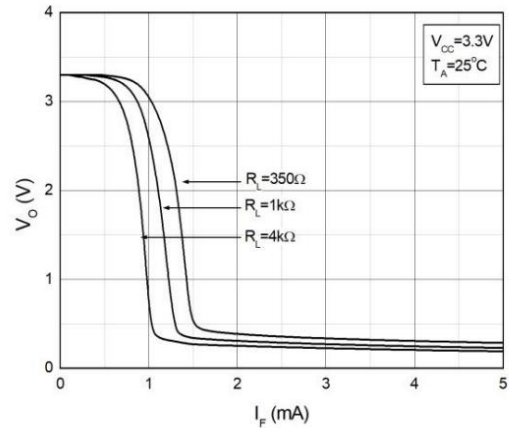

图例 12-输出电压与正向电流曲线图

Fig.12-Output Voltage vs. Forward Current

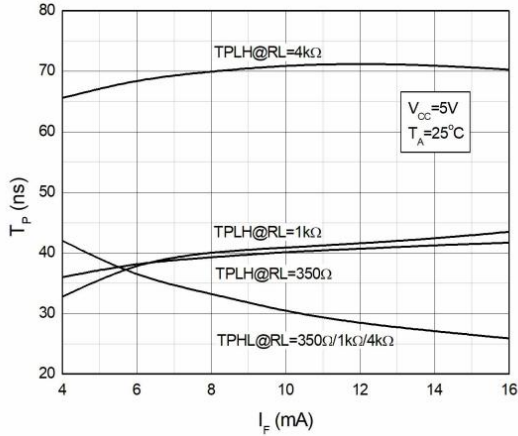

图例 13-输出传输延时与正向电流曲线图

Fig.13 Propagation Delay vs. Forward Current

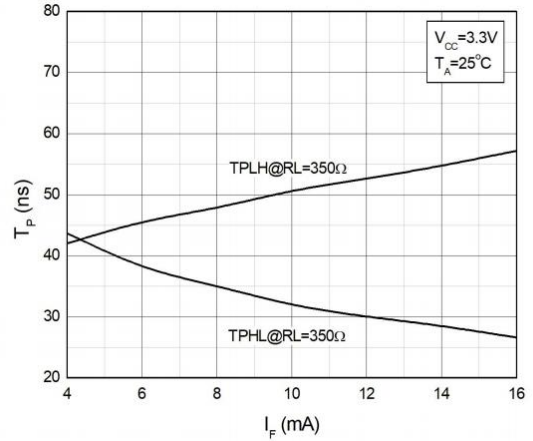

图例 14-输出传输延时与正向电流曲线图

Fig.14 Propagation Delay vs. Forward Current

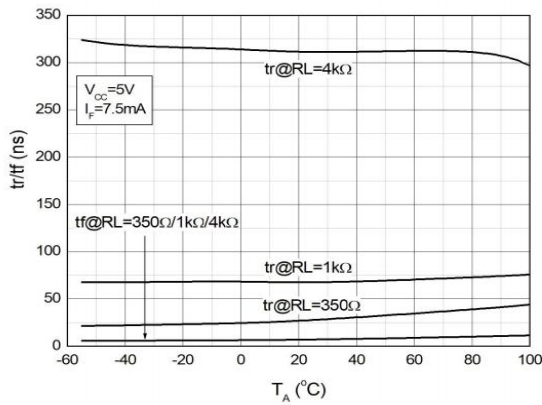

图例 15-输出上升和下降时间与环境温度曲线图

Fig.15 Rise and Fall Time vs. Ambient Temperature

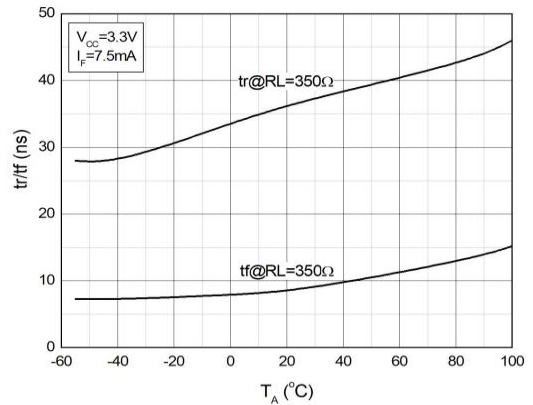

图例 16-输出上升和下降时间与环境温度曲线图

Fig.16 Rise and Fall Time vs. Ambient Temperature

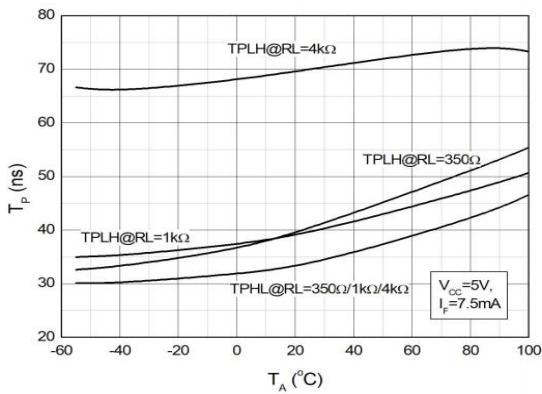

图例 17-输出传输延时与环境温度曲线图

Fig.17 Propagation Delay vs. Ambient Temperature

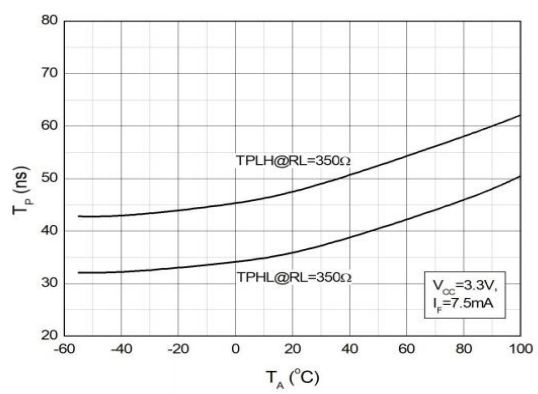

图例 18-输出传输延时与环境温度曲线图

Fig.18 Propagation Delay vs. Ambient Temperature

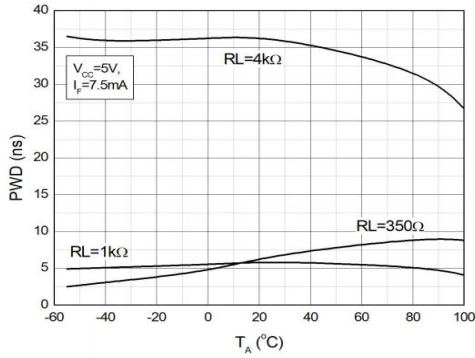

图例 19-脉宽失真与环境温度曲线图

Fig.19 Pulse Width Distortion vs. Ambient Temperature

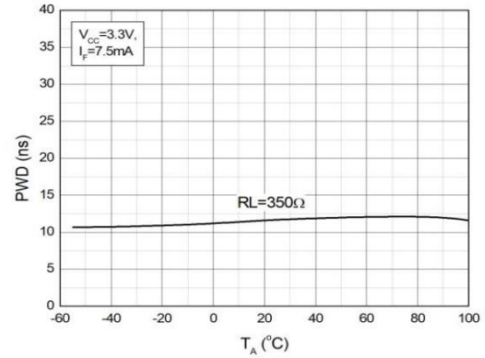

图例 19-脉宽失真与环境温度曲线图

Fig.20 Pulse Width Distortion vs. Ambient Temperature

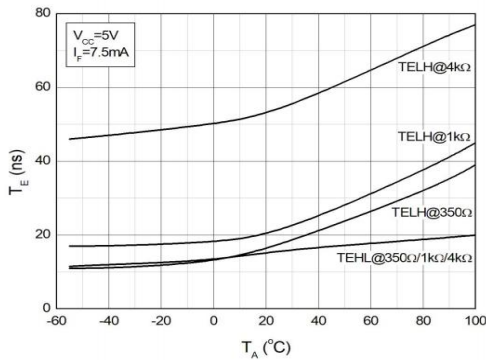

图例 21-输出电平使能传输延时与环境温度曲线图

Fig.21 Enable Propagation Delay vs. Ambient Temperature

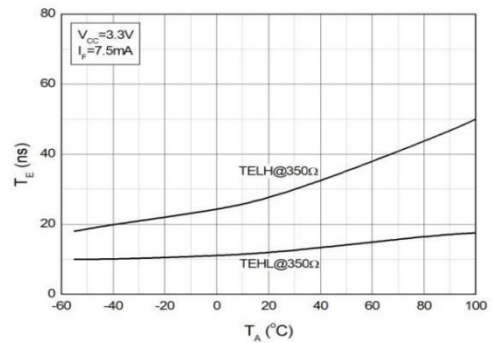

图例 22-输出电平使能传输延时与环境温度曲线图

Fig.22 Enable Propagation Delay vs. Ambient Temperature

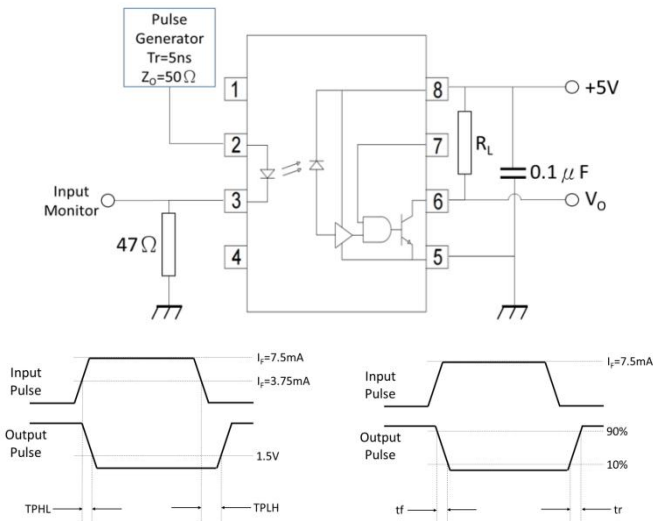

图例 23-输出传输延时测试电路与波形图

Fig.23 Test Circuits and Waveforms for TPHL, TPLH, tr, tf

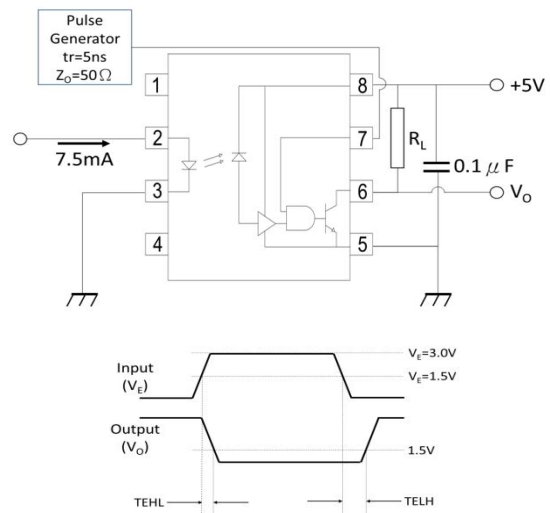

图例 24-输出使能传输延时测试电路与波形图

Fig.24 Test Circuits and Waveforms for TEHL, TELH

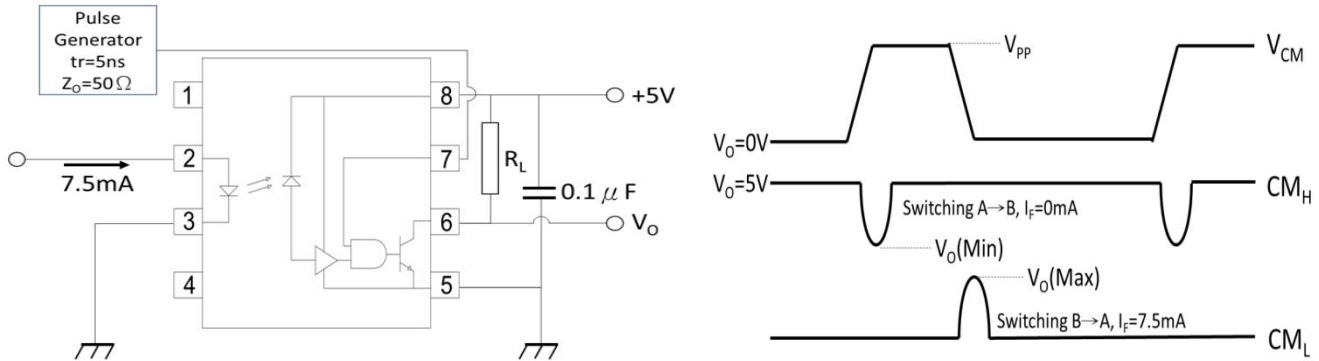

图例 25-输出共模抑制因子测试电路与波形图

Fig.25 Test Circuits for Common Mode Transient Immunity

印字信息 Marking Information

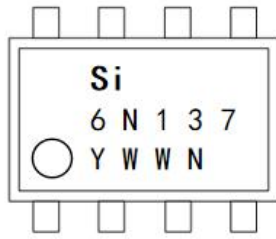

- ◆ Si:生产商代码 Manufacturer's Code Marking
- ◆ 6N137: 器件型号代码 Device Part Number
- ◆ Y: 年份代码 Last Digit of Year (ex: 4=2024, 5=2025)
- ◆ WW: 周号代码 Week Code (01 to 53)
- ◆ N:特殊代码 Special code or None

命名规则 Naming Rule

Si-6N137-WY-ZTT

- ◆ Si: 生产商代码 Manufacturer's Code Marking
- ◆ 6N137: 器件型号代码 Device Part Number
- ◆ W:框架材质 (C=铜)
- ◆ Y:G/None (G=环保, None=非环保)
- ◆ Z:封装形式 (Z=D:DIP8、Z=S:SMD8)
- ◆ TT: 补充码 A~Z or 0~9 or None

封装外形尺寸 Package Outline Dimensions

DIP8

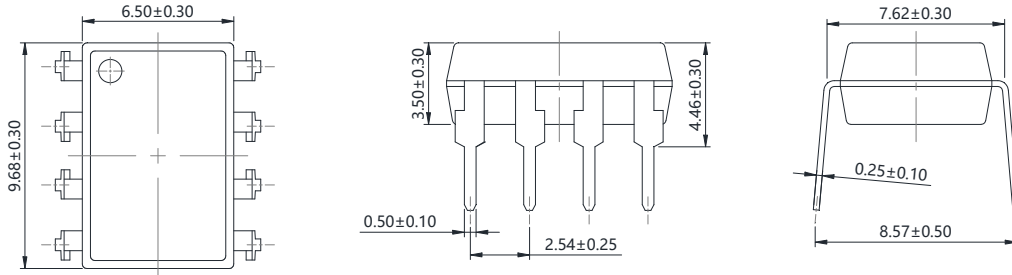

SMD8

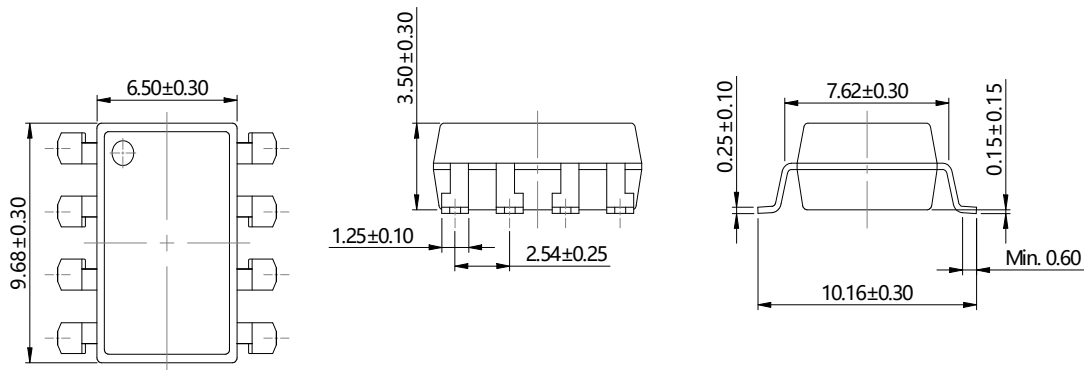

单位 Unit: mm

推荐焊盘尺寸 Recommended Footprint Patterns

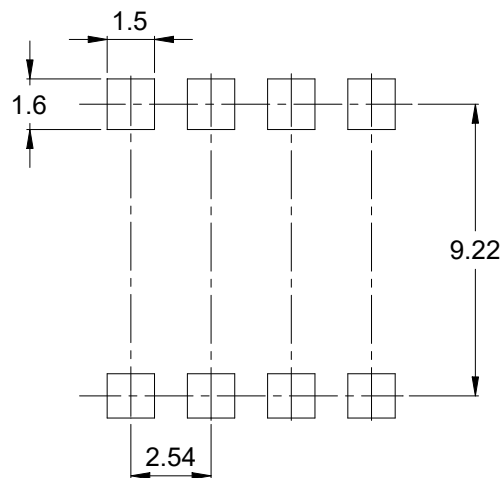

包装载带与卷盘 Packing Tape and Reel

封装类型 Package Type	每管数量 Quantity per Tube	内盒数量 Quantity per Inner Box	外箱数量 Quantity per Carton	内盒尺寸 Inner Box Dimensions	外箱尺寸 Carton Dimensions
Dip8	40 pcs/tube	1200pcs/inner box	12000 pcs/carton	525*107*47mm	535*235*255mm

封装类型 Package Type	每盘数量 Quantity per Reel	内盒数量 Quantity per Inner Box	外箱数量 Quantity per Carton	内盒尺寸 Inner Box Dimensions	外箱尺寸 Carton Dimensions
SMD8	1000 pcs/reel	3000 pcs/inner box	15,000 pcs/carton	360*360*69mm	450*380*380mm

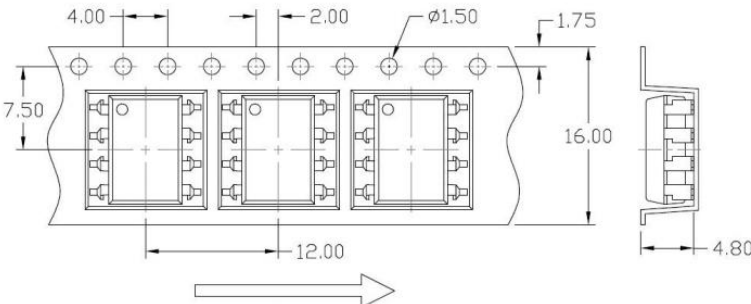
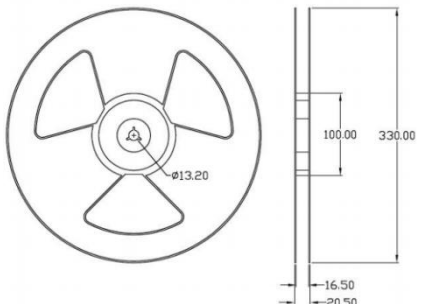
封装类型 Package Type	载带尺寸 Tape Dimensions	卷盘尺寸 Dimensions of Tape Reel
SMD8		

回流焊温度曲线 Solder Reflow Temperature Profile

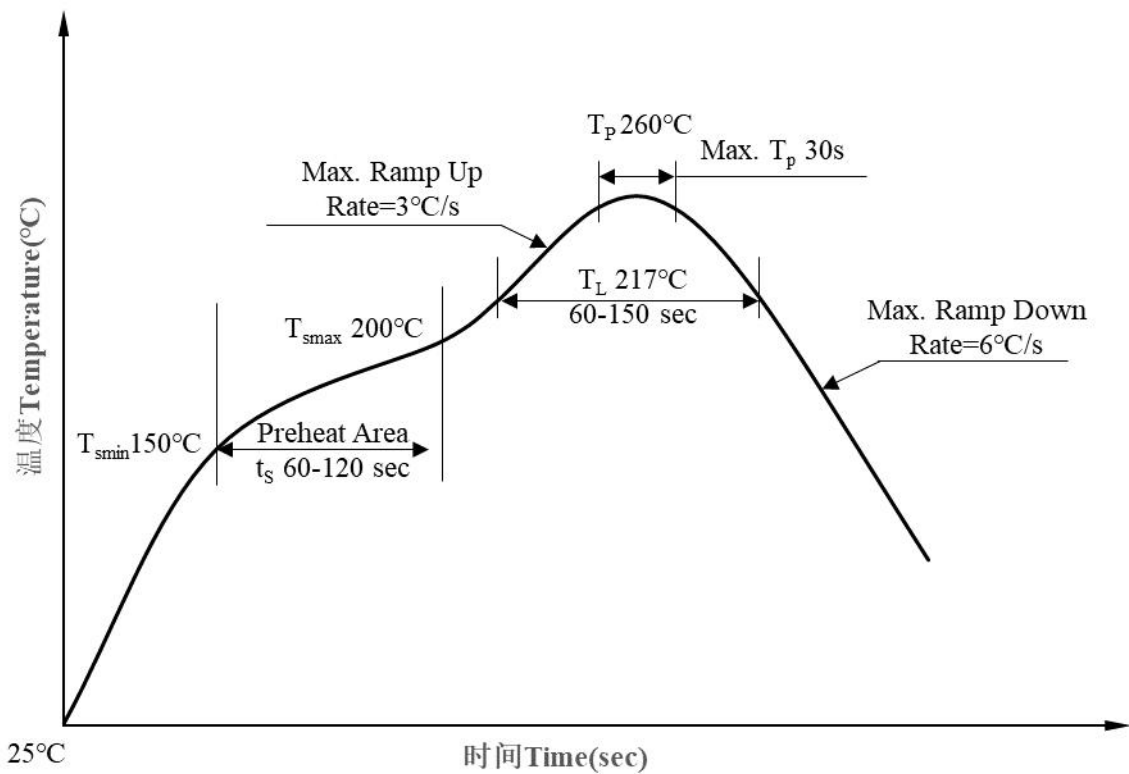

曲线项目 Profile Item		符号 Symbol	数值 Value	单位 Unit
预热区 Preheat Area	最低温度 Temperature Min.	T_{smin}	150	°C
	最高温度 Temperature Max.	T_{smax}	200	°C
	时间 Time (min. to max.)	t_s	60~120	sec
焊接区 Soldering Area	温度 Temperature	T_L	217	°C
	时间 Time	t_L	60~150	sec
峰值温度 Peak Temperature		T_p	260	°C
峰值温度 T_p 至 $T_p-5^\circ\text{C}$ 之间的时间 Time within 5 °C of Peak Temperature: $T_p - 5^\circ\text{C}$		t_p	30	sec max.
上升速率 Ramp-up rate		-	3	°C / sec max.
下降速率 Ramp-down rate		-	6	°C / sec max.

注：参考 IPC/JEDEC J-STD-020D 标准。

Note: Reference: IPC/JEDEC J-STD-020D.

建议在所示的温度和时间条件下进行回流焊，最多不能超过三次。

One time soldering reflow is recommended within the condition of temperature and time profile shown below. Do not solder more than three times.

波峰焊温度曲线 Wave soldering Temperature Profile

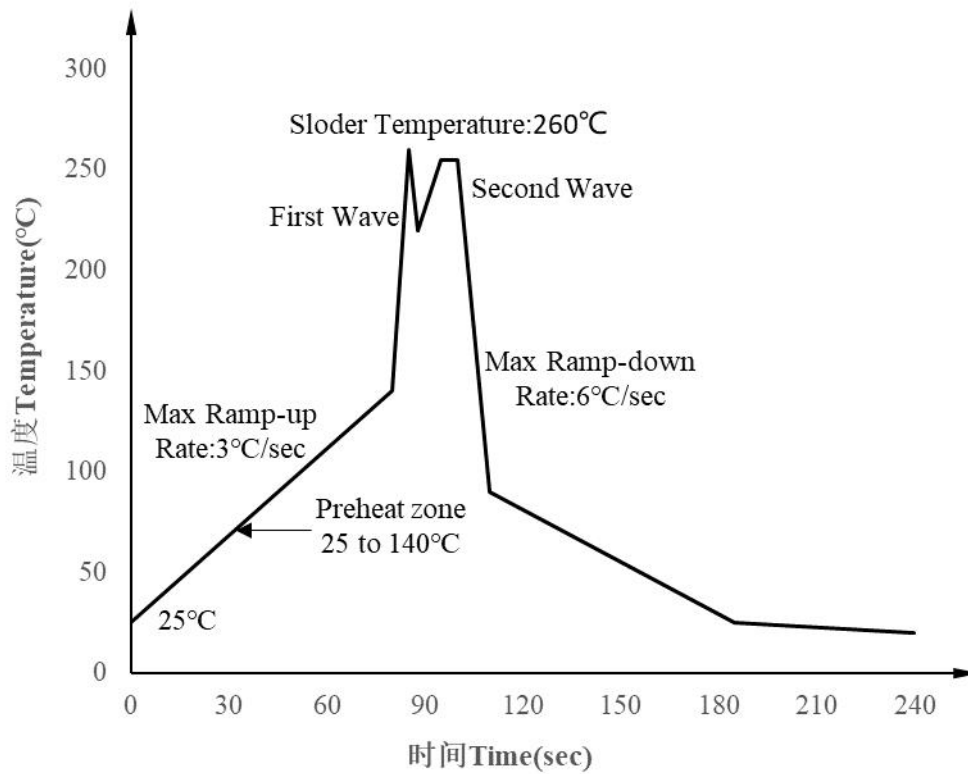

详情请参考 JEDEC 标准 JESD22-A111

For more details, please refer to the JESD22-A111 of JEDEC standards.

手工烙铁焊接 Hand soldering by soldering iron

(1) 建议一次完成焊接。

One time soldering is recommended.

(2) 温度 $360^{\circ}\text{C} \pm 5^{\circ}\text{C}$, 时间 $\leq 3\text{s}$ 。

Temperature: $360^{\circ}\text{C} \pm 5^{\circ}\text{C}$, within 3s.

声明 Disclaimer

1. 为提高产品可靠性、功能或设计或其他方面，硅耐所有产品规格可能会进行更改，恕不另行通知。
Silicon nice all product specifications are subject to change without notice to improve reliability, function or design or otherwise.
2. 使用本产品时请遵守规格书中的说明，硅耐对使用不符合这些规格表中说明的产品造成的损坏不承担任何责任。
When using this product, please observe the instructions in this specifications. Silicon nice assumes no responsibility for any damage resulting from use of the product which does not comply with the instructions included in this specification sheets.
3. 本规格书所展示的产品为电子应用中的一般用途而设计，如办公自动化设备、通信设备、音频/视频设备、电气应用和仪器仪表等。
The products shown in this specifications are designed for the general use in electronic applications such as office automation equipment, communications devices, audio/visual equipment, electrical application and instrumentation,etc.
4. 对于需要高可靠性或安全性的设备/装置，如太空应用、核电控制设备、医疗设备、任何“特定”应用等，请联系我们的销售代表。
For equipment/devices where high reliability or safety is required, such as space applications, nuclear power control equipment, medical equipment, any "specific" application,etc, please contact our sales representatives.
5. 如对文件中表述的内容有疑问，欢迎联系我们。
If you have any questions about the contents of the document, please contact us.